



TAMPER-EVIDENTTM SQUARE



SAFE AND STURDY AS A PRIORITY

A tamper-evident security system and a space saver shape to simplify your operations. Ideal for deli such as prepared salads.

CERTIFICATIONS

The raw materials used are tested according to ASTM standards for polymers, are approved for food contact and meet FDA (Food and Drug Administration, USA) and HPB (Health Protection Branch, Canada) regulations.



MINIMUM ORDERS INFORMATION

For details on minimum order quantities or for any other additional information, please contact IPL customer care at 1-800-647-0602 or visit our web site at www.ipl-plastics.com.

KEY FEATURES AND BENEFITS

- Tamper-evident security system
- Easy to open and use
- Hot filling capable
- Large decoration surface
- Photo quality IML graphics
- Microwave and dishwasher safe

MATERIAL

Containers, lids and IML labels are made of 100% recyclable polypropylene (PP).



DECORATION AVAILABLE

- **Container:**
 - Full IML wrap except for 8oz.
 - Dry offset for all sizes
- **Bottom:**
 - IML except 8oz. and 48 oz.
 - Dry offset for all sizes
- **Lid:**
 - Full IML
 - Dry offset

COLOR CODE

BASE COLORS	STANDARD COLORS	OTHER COLORS
Natural 000	Black 099	Available upon request
White 001	Yellow 012	
Clear 002	Orange 021	
	Red 485	
	Green 377	
	Blue 293	



Our containers are 100% recyclable because at IPL, we care about the environment.





CONTAINERS

PRODUCT CODE	MODEL / NOMINAL*	UNDER LID CAPACITY		APPROX. WEIGHT		A OVERALL HEIGHT		B OVERALL WIDTH		ITEMS PER BOX	BOXES PER PALLET	ITEMS PER PALLET
		US fl. oz.	ml	oz.	g	in.	mm	in.	mm			
22595	8 oz. / 250 ml	8.93	264	0.53	15.2	1.62	41.27	4.25	107.95	900	16	14,400
23595	12 oz. / 350 ml	13.59	402	0.72	20.3	2.25	57.15	4.25	107.95	720	16	11,520
25095	16 oz. / 500 ml	17.38	514	0.77	22	3.00	76.20	4.25	107.95	700	16	11,200
21145	32 oz. / 1 L	33.81	1,000	1.16	33	3.00	76.20	5.81	147.65	420	16	6,720
21545	48 oz. / 1.5 L	52.41	1,550	1.76	50	4.56	115.90	5.81	147.65	300	16	4,800

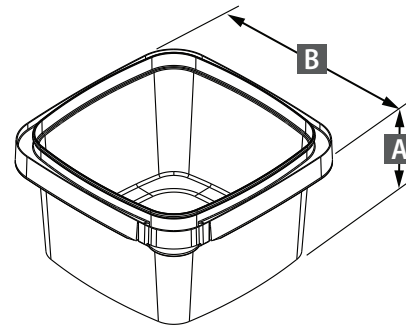

LIDS

PRODUCT CODE	MODEL - ASSOCIATED CONTAINERS	APPROX. WEIGHT		HEIGHT		WIDTH		ITEMS PER BOX	BOXES PER PALLET	ITEMS PER PALLET
		oz.	g	in.	mm	in.	mm			
20095	8 oz. / 250 ml, 12 oz. / 350 ml, 16 oz. / 500 ml	0.25	7.2	0.25	6.35	4.12	104.77	1,350	35	47,250
20145	32 oz. / 1 L, 48 oz. / 1.5 L	0.52	14.5	0.25	6.35	5.62	142.87	900	32	28,800

RECOMMENDATIONS

Handling conditions vary from customer to customer. We recommend validating your processes (filling, conveying, warehousing and any others that might affect the purchased part) prior to use. Product usage temperature is between -9.4°F (-23°C) and 179.6°F (82°C) depending on resin grade.

WARRANTIES

- Some chemicals can affect the integrity of the product. Any product requiring a Safety Data Sheet (SDS) has to be submitted and approved by IPL. If buyer fails to adhere to this clause, the related product guarantees will be void.
- Specifications may vary slightly over time. Please contact your IPL representative to ensure you have the most recent information.
- The information presented herein was prepared at IPL Inc. by qualified technical personnel. To IPL's knowledge, it is true and accurate. However, the information and recommendations are furnished for these products with the understanding that the purchaser or user will independently determine that the product is suitable for the intended use, and that such use, complies with all applicable laws and regulations. The data represents typical values submitted only for the user's information and consideration and does not constitute a warranty of any kind.

