



Consumer Packaging

TAMPER-EVIDENT SQUARE SERIES
8 OZ. / 250 ML TO 48 OZ. / 1.5 L



FOOD MANUFACTURING AND PROCESSING

Safety as a priority.

Tamper-Evident Square

Safety as a priority



We don't just make containers, we understand the importance of reaching and attracting your customers at the point of purchase.

Features

- Tamper-evident security system
- Easy to open and use
- Suitable for hot fill
- Photo-quality IML and dry offset decoration
- Space saving compared to round
- Microwave and dishwasher safe
- 100 % recyclable polypropylene

TAMPER-EVIDENT SQUARE SERIES

Features our original tamper-evident security system to simplify your operations. Ideal for dairy, deli and any other product.

For every need

Deli

Salads, soups, sauces, dips, other refrigerated products.

Dairy

Cultured dairy, cheese, spreads, shredded cheese.

Other

Grocery, club store, food service, hardware, household cleaning, pet food, lawn & garden.



Mod.: 22595
8 oz. - (250 ml)
4.28" (W) X 1.63" (H)



Mod.: 23595
12 oz. - (350 ml)
4.28" (W) X 2.39" (H)



Mod.: 25095
16 oz. - (500 ml)
4.28" (W) X 3.00" (H)



Mod.: 21145
32 oz. - (1 L)
5.84" (W) X 3.00" (H)



Mod.: 21545
48 oz. - (1.5 L)
5.84" (W) X 4.51" (H)

Tamper-Evident Square Specifications

www.iplglobal.com
1-800-647-0602
info.cps@iplglobal.com

CONTAINERS

Product Code	Model	Decoration Options†		Under Lid Capacity		Approx. Weight		Overall Height	A	Overall Width	B	Items Per Box	Boxes Per Pallet	Items Per Pallet
		IML	Offset	US fl.oz.	ml	oz.	g	in.	mm	in.	mm			
22595	8 oz. / 250 ml		✓ W	8.79	260	0.56	15.9	1.63	41.4	4.28	108.7	900	16	14,400
23595	12 oz. / 350 ml	✓ W/B	✓ W	13.62	403	0.70	20.0	2.39	60.8	4.28	108.7	720	16	11,520
25095	16 oz. / 500 ml	✓ W/B	✓ W	17.25	510	0.77	21.9	3.00	76.1	4.28	108.7	700	16	11,200
21145	32 oz. / 1 L	✓ W/B	✓ W	33.81	1,000	1.20	34.2	3.00	76.1	5.84	148.3	420	16	6,720
21545	48 oz. / 1.5 L	✓ W	✓ W	51.00	1,508	1.72	48.7	4.51	114.4	5.85	148.7	300	16	4,800

LIDS

Product Code	Associated Containers Code	Decoration Options		Approx. Weight		Height	A	Width	B	Items Per Box	Boxes Per Pallet	Items Per Pallet
		IML	Offset	oz.	g	in.	mm	in.	mm			
20095	22595, 23595, 25095	✓	✓	0.25	7.23	0.28	7.1	4.14	105.2	1350	35	47,250
20145	21145, 21545	✓	✓	0.47	14.9	0.29	7.3	5.60	142.3	900	32	28,800

Color Options

Base Colors	Other Colors
Natural	Available on request
White	
Clear	

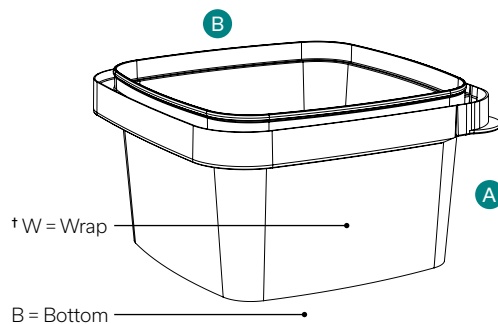

About

IPL inc. Consumer Packaging Solutions is a division of IPLP Group. To learn more, visit www.iplglobal.com.

Project?

Not sure you found what you need?
Need a custom design?
Get in touch with one of our retail and consumer packaging expert!
info.cps@iplglobal.com
www.iplglobal.com
1-800-647-0602

Certifications

The raw materials used are tested according to ASTM standards for polymers, are approved for food contact and meet FDA (Food and Drug Administration, USA) and HPB (Health Protection Branch, Canada) regulations. Our facilities and rigorous quality control processes have earned us certification under the following standards: ISO 9001, HACCP, IMS, SQF, C-TPAT & ISO 14001 registered management system.

Terms and conditions

For warranties, handling, processing, filling and testing recommendations, please refer to our full terms and conditions sheet available upon request.