



Consumer Packaging



SEALPACK EXPO 410
12 OZ. / 350 ML

INJECTION MOLDED THIN WALL PACKAGING

A 410 opening container
with a modern and
distinctive shape.

SealPack Expo 410

Large billboard decoration to showcase your brand



We don't just make containers, we understand the importance of reaching and attracting your customers at the point of purchase.

NEW ADDITION TO THE ESTABLISHED SEALPACK FAMILY

An ideal packaging solution for cheese spreads, dips, hummus and plant-based alternatives. Its modern shape stands out from the competition while offering a large branding billboard with wrap around IML decoration.

Ideal for

Specialty cheese

Cheese spreads, dips, fresh cheese in brine and shredded cheese

Deli

Salads, soups, sauces, dips, olives and other refrigerated products

Dairy

Cultured dairy, yogurt, spreads

Plant-based

Dairy-free cheeses, spreads and other plant-based alternatives

Features

- 410 opening
- Film-sealable
- Photo-quality IML decoration
- Suitable for hot-fill application
- A modern and distinguishable shaped container
- Additional sizes can be developed upon request
- 100% recyclable polypropylene

Benefits

- Easy transition from other existing 410 opening packaging solutions
- Large branding billboard with wrap around IML decoration



23567
12 oz. - 350 ml
4,600" (D) X 2,362" (H)

SealPack Expo 410 Specifications

www.iplglobal.com
 1-800-647-0602
 info.cps@iplglobal.com

CONTAINER

Product Code	Model	Decoration Options†		Under Lid Capacity		Approx. Weight		Overall Height	A	Overall Width	B	Items Per Box	Boxes Per Pallet	Items Per Pallet
		IML	Offset	US fl.oz.	ml	oz.	g	in.	mm	in.	mm			
23567	12 oz. / 350 ml	✓	W	14.8	438	0.44	12.5	2.36	60	4.6	116.8	1,000	24	24,000

LID

Product Code	Associated Containers Code	Decoration Options		Approx. Weight		Overall Height	A	Overall Width	B	Items Per Box	Boxes Per Pallet	Items Per Pallet
		IML	Offset	oz.	g	in.	mm	in.	mm			
20124	23567	✓	✓	0.23	6.5	0.30	7.7	4.64	117.8	1,500	20	30,000

Color Options

Base Colors	Other Colors
Natural	Available upon request
White	
Clear	

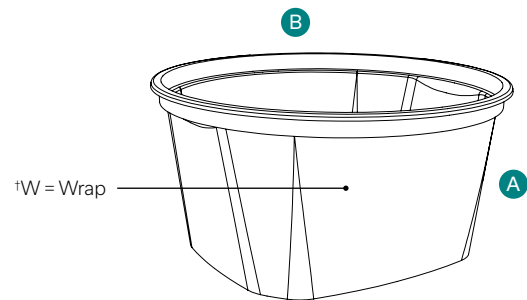

About

IPL inc. Consumer Packaging Solutions is a division of IPLP Group. To learn more, visit www.iplglobal.com.

Project?

Not sure you found what you need?
 Need a custom design?
 Get in touch with one of our retail and consumer packaging expert!
info.cps@iplglobal.com
www.iplglobal.com
 1-800-647-0602

Certifications

The raw materials used are tested according to ASTM standards for polymers, are approved for food contact and meet FDA (Food and Drug Administration, USA) and HPB (Health Protection Branch, Canada) regulations. Our facilities and rigorous quality control processes have earned us certification under the following standards: ISO 9001, HACCP, IMS, SQF, C-TPAT & ISO 14001 registered management system.

Terms and conditions

For warranties, handling, processing, filling and testing recommendations, please refer to our full terms and conditions sheet available upon request.